

I B.Tech - Regular Examinations, June 2009

NETWORK ANALYSIS

(Common to Electronics & Communication Engineering, Electronics & Instrumentation Engineering, Bio-Medical Engineering, Electronics & Control Engineering, Electronics & Computer Engineering)

Time: 3 hours

Max Marks: 80

Answer any FIVE Questions
All Questions carry equal marks

1. Using star delta conversion find the current I in the circuit as shown in figure 1.

[16]

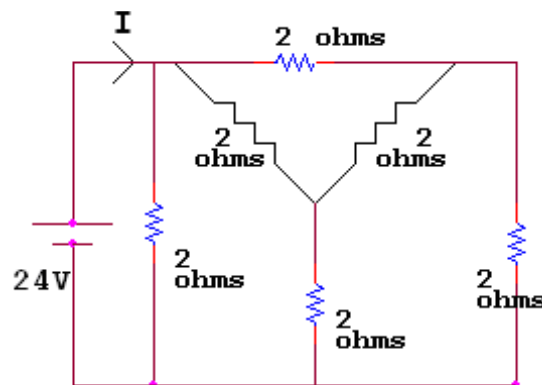

Figure 1

2. The resistor R in series with capacitance C is connected to a 50Hz, 240 V supply. Find the value of C so that R absorbs 300 watts at 100 volts. Find also the maximum charge and the maximum stored energy in C. [16]
3. Derive the expression for resonant frequency of a parallel circuit having R_1 and L in one branch and R_2 and C in the second branch. [16]
4. Find the power delivered by the batteries in the figure 4 using mesh analysis. [16]

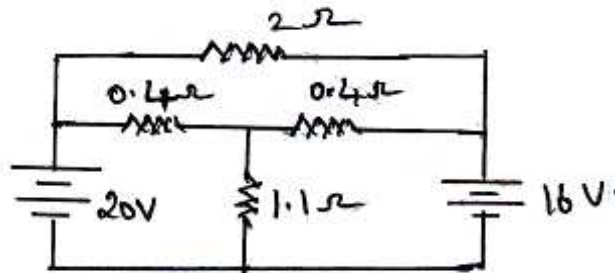

Figure 4

5. Find the value of R_L so that maximum power is delivered to the load resistance R_L , as shown in figure 5. Also calculate maximum power. [16]

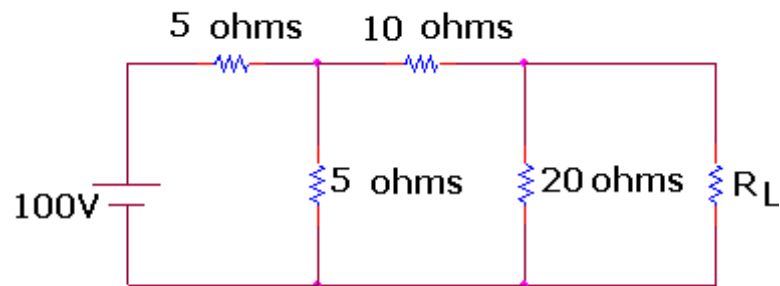

Figure 5

6. For the two port network shown in the figure 6, the currents I_1 and I_2 entering at port 1 and 2 respectively are given by the equations.

$$I_1 = 0.5 V_1 - 0.2 V_2$$

$$I_2 = -0.2V_1 + V_2$$

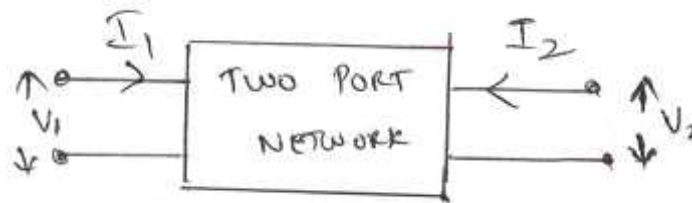

Figure 6

Where V_1 and V_2 are the port voltages at port 1 and 2 respectively. Find the Y, Z, ABCD parameters for the network. Also find its equivalent Π network. [16]

7. Derive the transient response of RLC series circuit with unit step input. [16]
8. Design a T-type and π -type attenuator if the characteristic resistance is 200Ω and the attenuation is 200dB. [16]

I B.Tech - Regular Examinations, June 2009

NETWORK ANALYSIS

(Common to Electronics & Communication Engineering, Electronics & Instrumentation Engineering, Bio-Medical Engineering, Electronics & Control Engineering, Electronics & Computer Engineering)

Time: 3 hours

Max Marks: 80

Answer any FIVE Questions
All Questions carry equal marks

1. A circuit consisting of three resistances $12\ \Omega$, $18\ \Omega$ and $36\ \Omega$ respectively joined in parallel is connected in series with a fourth resistance. The whole circuit is applied with 60V and it is found that the power dissipated in the $12\ \Omega$ resistor is $36\ \text{W}$. Determine the value of the fourth resistance and the total power dissipated in the circuit. [16]
2. The number of turns in a coil is 20. When a current of 2A flows in this coil, the flux in the coils is $0.3\ \text{mwb}$. When this current is reduced to zero in 2 milli seconds, the voltage induced in an adjacent coil is 63.75V . If $K = 0.85$, find self inductances of the two coils, mutual inductance and number of turns in the second coil. [16]
3. A balanced 3 phase star connected load of 150kW takes a leading current of 100A with line voltage of $1100\ \text{volts}$, $50\ \text{Hz}$. Find the circuit constant of the load per phase. [16]
4. For the network, shown in figure 4 draw the oriented graph and obtain the cut set matrix. [16]

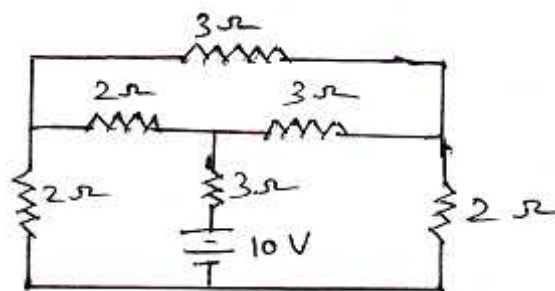

Figure 4

5. (a) State and explain Thevenin's Theorem.
(b) What are the limitations of Thevenin's Theorem.
(c) Explain the steps to apply Thevenin's Theorem and draw the Thevenin's equivalent circuit. [6+4+6]
6. For the two port network shown in the figure 6, the currents I_1 and I_2 entering at port 1 and 2 respectively are given by the equations.
 $I_1 = 0.5 V_1 - 0.2 V_2$

$$I_2 = -0.2V_1 + V_2$$

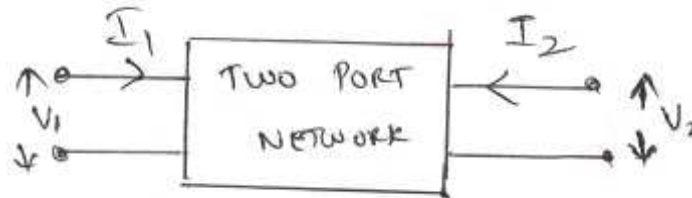

Figure 6

Where V_1 and V_2 are the port voltages at port 1 and 2 respectively. Find the Y, Z, ABCD parameters for the network. Also find its equivalent Π network. [16]

7. In the circuit shown in figure 7, $E_g(t) = 2.5t$ Volts. What are the values of $i(t)$ and $V_L(t)$ at $t = 4$ seconds. [16]

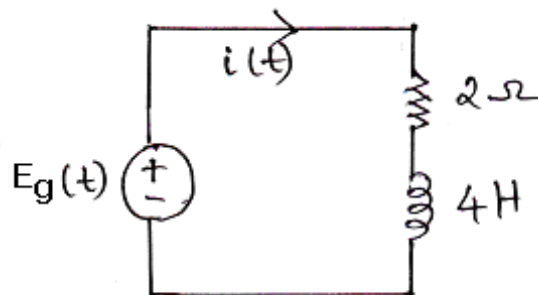

Figure 7

8. A high pass filter section is constructed from two capacitors $1 \mu\text{F}$ each and a 15 mH inductance. Find the cut - off frequency, infinite frequency characteristic impedance and characteristic impedance at 200 Hz , attenuation at 200 Hz and phase shift constant at 200 Hz . [16]

I B.Tech - Regular Examinations, June 2009**NETWORK ANALYSIS**

(Common to Electronics & Communication Engineering, Electronics & Instrumentation Engineering, Bio-Medical Engineering, Electronics & Control Engineering, Electronics & Computer Engineering)

Time: 3 hours

Max Marks: 80

Answer any FIVE Questions
All Questions carry equal marks

1. (a) Explain source transformation with examples.
(b) Two resistors are connected in parallel and a voltage of 200 volts is applied to the terminals. The total current taken is 25A and the power dissipated in one of the resistors is 1500W. What is the resistance of each element? [5+11]
2. What is coefficient of coupling? How can it be varied? Derive an expression for the same. [16]
3. A parallel circuit has two branches, branch 1 has a resistance of 5Ω connected in series with an inductance 10 mH. A capacitor is connected in branch 2, the parallel circuit is connected across a 230 V, 50Hz supply. If the circuit is to be in resonance find the value of the capacitance. Find the current drawn from the supply and also find the currents in branches 1 and 2. Draw the vector diagram. [16]
4. Find the currents in all resistors for the network, shown in figure 4 using loop analysis method. [16]

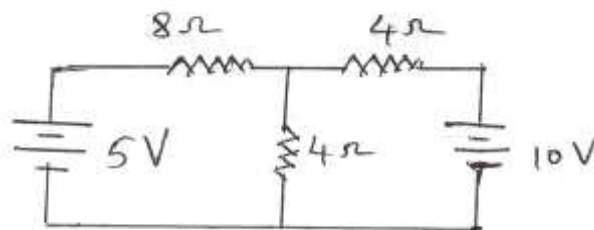

Figure 4

5. Using Norton's theorem, find the current through the load impedance Z_L , for the network as shown in figure 5. [16]

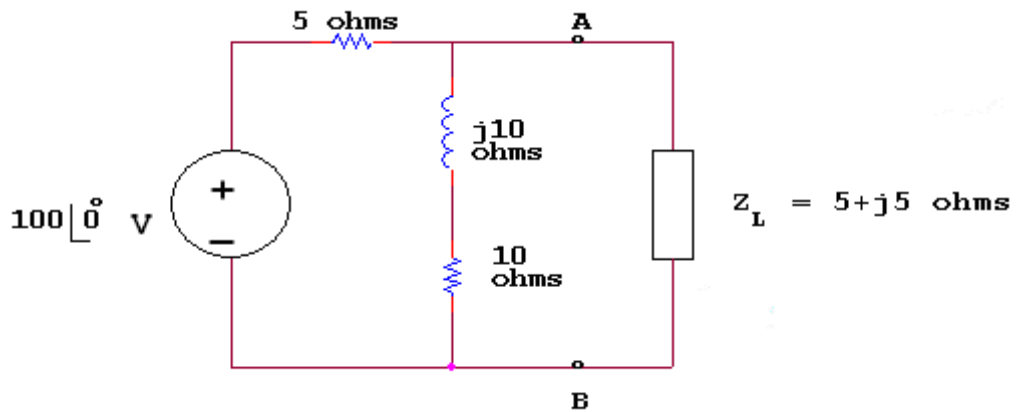

Figure 5

6. Find the hybrid and y-parameters for the network shown in figure 6. [16]

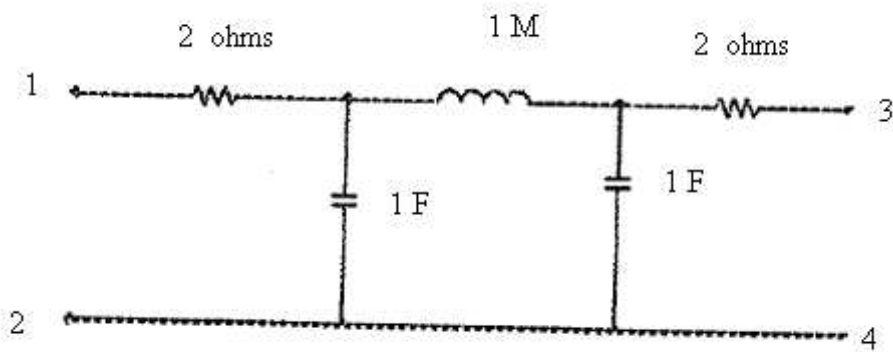

Figure 6

7. In the circuit shown in figure 7, $E_g(t) = 2.5 t$ Volts. What are the values of $i(t)$ and $V_L(t)$ at $t = 4$ seconds. [16]

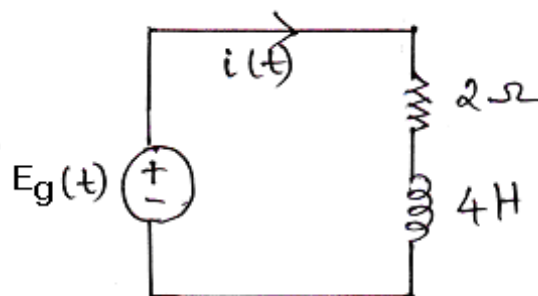

Figure 7

8. Design a composite low pass filter to meet the following specifications. The filter is to be terminated in 500 ohms resistance and it is to have a cutoff of 1000 Hz with very high attenuation at 1065 and 1250 Hz. [16]

I B.Tech - Regular Examinations, June 2009

NETWORK ANALYSIS

(Common to Electronics & Communication Engineering, Electronics & Instrumentation Engineering, Bio-Medical Engineering, Electronics & Control Engineering, Electronics & Computer Engineering)

Time: 3 hours

Max Marks: 80

Answer any FIVE Questions
All Questions carry equal marks

1. A circuit consisting of three resistances $12\ \Omega$, $18\ \Omega$ and $36\ \Omega$ respectively joined in parallel is connected in series with a fourth resistance. The whole circuit is applied with 60V and it is found that the power dissipated in the $12\ \Omega$ resistor is 36 W . Determine the value of the fourth resistance and the total power dissipated in the circuit. [16]
2. For the trapezoidal waveform shown in the figure 2b, determine [16]
 - (a) Average value
 - (b) R.M.S. Value.

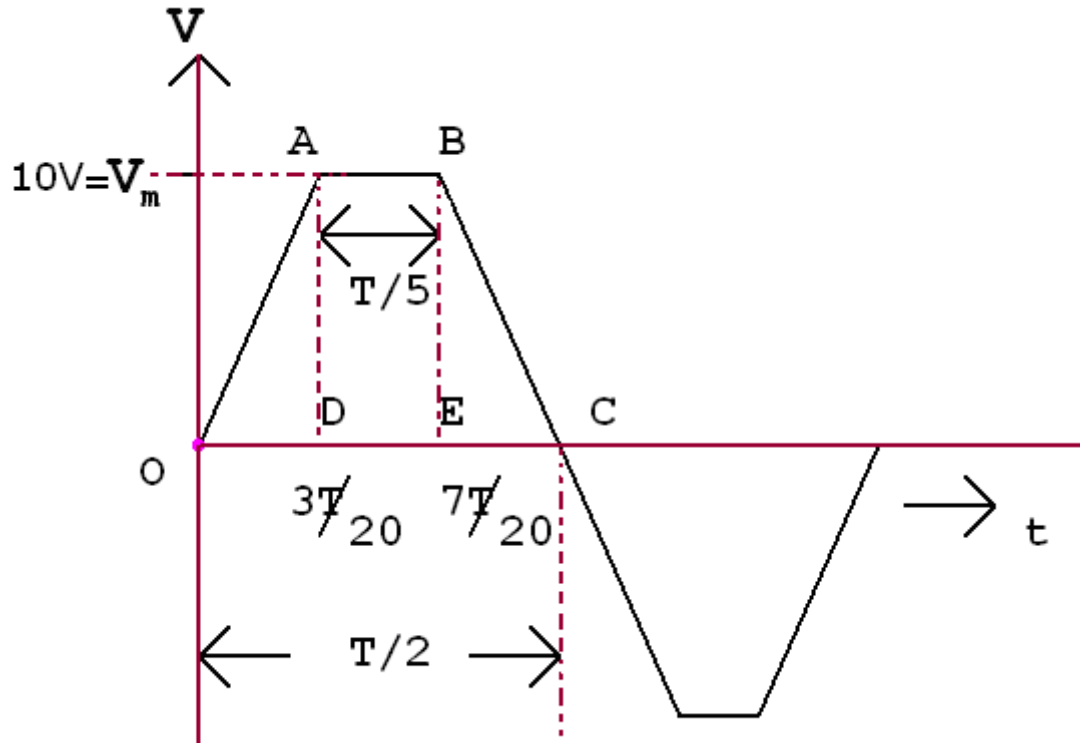

Figure 2b

3. Obtain the relationship between currents and the relationship between voltages in a delta connected system. Hence derive the equation for power in such a system. [16]

4. Obtain the cut - set matrix for the network, as shown in figure 4. [16]

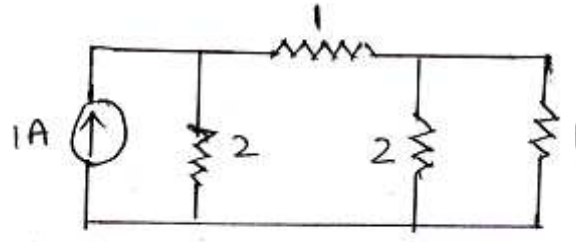

Figure 4

5. Find V_a using Super position principle in the circuit shown in the figure 5. [16]

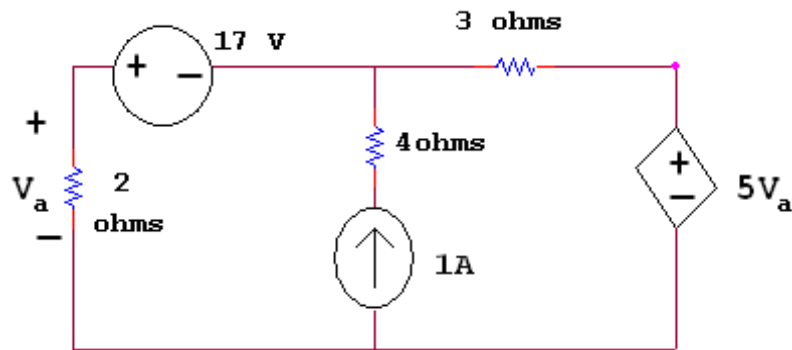

Figure 5

6. For the circuit shown in figure 6, find the h parameters and ABCD parameters. Check for reciprocity. [16]

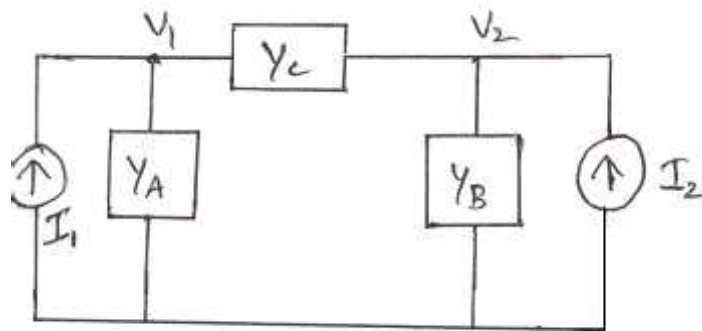

Figure 6

7. A DC voltage of 100V is applied in the adjoining circuit as shown in the figure 7 and the switch K is open. The switch K is closed at $t = 0$. Find the complete expression for the current. [16]

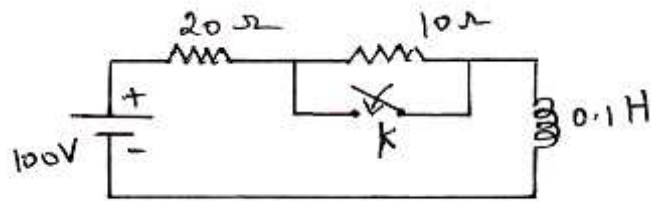

Figure 7

8. Design a composite low pass filter to meet the following specifications. The filter is to be terminated in 500 ohms resistance and it is to have a cutoff of 1000 Hz with very high attenuation at 1065 and 1250 Hz. [16]
